

GE Consumer & Industrial
Power Protection

Technical data sheets

Digital Energy™ Uninterruptible Power Supply LP 11 Series / 3 – 5 – 6 – 8 – 10 kVA

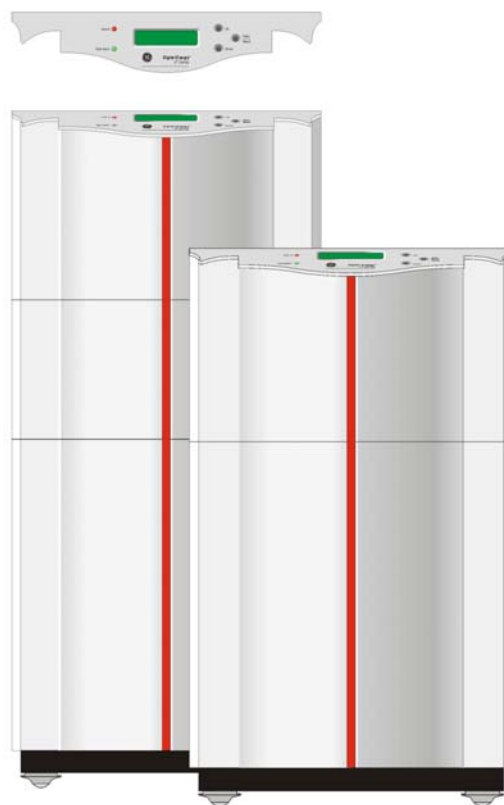

A product by:

GE Digital Energy
General Electric Company
CH - 6595 Riazzino (Locarno)
Switzerland
T +41 (0)91 / 850 51 51
F +41 (0)91 / 850 51 44

www.gedigitalenergy.com



GE imagination at work



General data						
Topology	VFI, double conversion					
Nominal output rating	kVA/kW	3/2.4	5/4	6/4.8	8/6.4	10/8
Overall efficiency at nominal load	%	86	88	88	88	89
Heat dissipation at inverter nominal load, PF=0.8. and charged battery	W	327	545	655	872	988
Cooling air (25°C - 30°C)	m ³ /h	330 max.				
Audible noise level	dB(A)	40-50 (EN 27779)				
Operating temperature range	-10°C - 40°C (15°C - 25°C recommended for battery)					
Storage temperature range	-20°C - +45°C					
Relative humidity	Max. 95% (non-condensing)					
Protection degree	IP 20 (IEC 60529 and DIN 40050)					
Safety	EN 50091-1-1, IEC/EN 60950, IEC/EN 62040-1					
EMC	EN 50091-2, IEC/EN 62040-2 Class A					
Surge capacity	IEC 61000-4-5 (6kV 1.2/50 µsec - 3kA 8/20µsec)					
Electrostatic discharge immunity	4kV contact / 8kV air discharge					
Transport	On pallet / rollers for installation					
Colour	Cubicle: RAL 9010 (white) Front panel: RAL 9006 (aluminum)					
Cable connections	On terminals, bottom-rear					
Cooling	Forced by regulated internal fans					

Input converter (rectifier + power factor correction)						
Nominal AC input voltage	220 - 240V L + N					
Input frequency range	40 - 70Hz					
Power factor	>0.99					
THDi	<10%					
Nominal input current (no charging, U _{in} = nominal)	A	12.1	19.8	23.7	31.6	39
Inrush current	None					
DC output voltage	380 V					

Battery charger						
Battery charging characteristic	IU (DIN 41773) constant current charging until floating voltage, then constant voltage charging + boost charge					
DC input voltage range	350 - 450 V					
DC output voltage	162.5/177V (3kVA), 271/295.5V (5/6/8/10kVA)					
Output current limitation	Adc	2.0	2.0	2.0	3.0	3.0
Recharge time	1.5 - 3 hours for 80% capacity					

Battery data						
Battery type	Sealed and maintenance free (VRLA=Valve Regulated Lead Acid)					
Float voltage at 25°C	162.5 / 271 V					
Number of 12V batteries (in standard version)	12x7Ah (3kVA) 20x7Ah (5/6kVA) 20x12Ah (8/10kVA)					
Standard backup time at nominal load PF=0.8	min	10	10	8	11	8
Standard backup extensions	See table on page 4					

Output converter (inverter)						
Input voltage range	270 - 400 V					
Nominal output power at PF=0.8	kVA	3	5	6	8	10
Nominal output power with resistive load	kW	2.4	4	4.8	6.4	8
Nominal AC output voltage	220 / 230 / 240V					
Output voltage waveform	Sine wave					
Output voltage tolerance:						
- static resistive load	+/- 1%					
- dynamic mean deviation over half cycle (load step 0-100-0%)	+/- 2%					
- with measured non-linear load 2.5:1	+/- 2%					
- recovery time to +/-1%	10ms					
Overload capability (battery operation)	110%: 20 min., 130%: 3.5 min., 150%: 2 min.					
Short circuit current capability (240ms)	A	32	45	50	67	100
Output frequency	50/60Hz (selectable)					
Output frequency tolerance	+/- 0.1%, unless synchronised with the utility					
Frequency tracking range	+/- 2, 4 or 6% of nominal, selectable					
Max. phase shift difference input-output	7°					
Harmonic distortion with linear load	1% max					
Harmonic distortion with non-linear load (EN 50091)	10% max. with measured crest factor 2.5:1					
Power factor range	Any lagging or leading power factor is permitted within the specified rating to PF=0.5					
Crest factor handling capability of a non-linear load	5:1					
Output power derating altitude	Up to 1000m no derating Above 1000m 12.5% per 1000m, max. 4000m					
Protection	Automatic shut down (or transfer to bypass if available) in case of: - low/high DC voltage - overtemperature - overload / short circuit Output protected against connection to the mains					
Short-circuit clearance capability	20% In within 10 ms with MCB class B					
Inverter bridge	PWM and IGBT technology					

Bypass						
Primary components	- Thyristor switch - Synchronisation circuit inverter/bypass mains					
Bypass voltage limits	+/- 10% of nominal					
Frequency tracking range	+/- 2, 4 or 6% of nominal, selectable					
Slew rate	1Hz/s or 5Hz/s, selectable					
Overload capability on bypass, 1 minute/10 minutes	A	27/18	45/30	65/45	73/60	90/75

Interfacing						
Potential free contacts	Four open-collector contacts signalling following alarms: - bypass active - mains failure - battery low - general alarm					
ComConnect port (on Delta 9 pin connector)	For serial communication					
Input terminals for	- Emergency shutdown - Battery extension MCB alarm wiring					

Note: all indicated values are typical. Variations may be found from one unit to another.

Controls, signals and alarms

Front

Operation/Alarm : green/red LED
LCD screen : 2 x 16 characters
Push-buttons
Buzzer (resettable)

Rear

3 option slots for : RS232 interface card (std installed)
: Potentialfree contacts*
: SNMP*
: RPA* redundant parallel architecture

On/off switch
Manual bypass switch
Input/Output terminals
DC connector for external batteries (not for LP 3-11)
Line circuit breaker
Bypass circuit breaker

* = option

The LCD screen shows UPS system data, status messages, alarm messages, settings.

Front panel

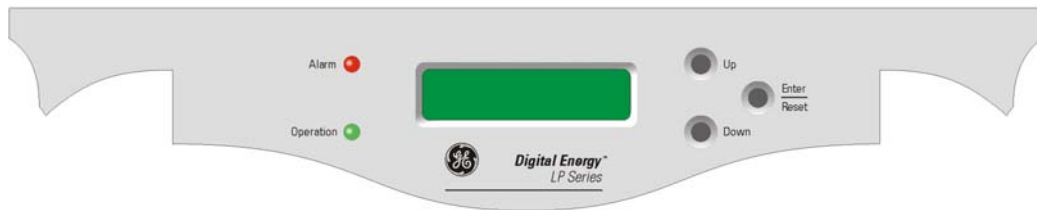

Optional features

SNMP interface card

An SNMP interface card can be placed in the rear panel of the UPS, and allows the data interface to be connected directly to an Ethernet network.

When this option is installed the ComProt communication link (serial communication) is no longer available to the user.

Relay card

The relay plug-in card can be installed in the rear panel of the UPS. The card is provided with four potential free contacts representing: battery low, bypass active, utility failure and general alarm.

Alarm boxes

An interface box linked to the ComConnect port, the VIC/RELAYBOX/01 translates the ComConnect signals to five independent changeover contacts, with a maximum switching capacity of 230V/5A each.

Wall mounted plastic alarm boxes are available for remote audible and visual alarm indication.

Connectivity products

A splitter box translates information from the ComConnect to several computers.

Interface kits (cables and/or software) are available for operating systems supporting JAVA and most commonly used network operating systems, including Novell, UNIX, VMS, Windows platforms, IBM AS/400, IBM OS/2, LINUX.

Please contact your dealer for specific information.

Battery extension packs

Except for the 3-11 model, the LP 11 UPS can be equipped with additional batteries to increase the runtime of the unit. These additional batteries are housed in a separate battery pack. Additional batteries will increase the recharging time for the unit. All other operational information is the same.

Battery packs can be connected in parallel to increase the runtime. DC connectors make installation of battery packs easy and simple.

Dimensions and battery

UPS Model	Backup time (min.)	Total capacity (Ah)	Nr. of extra battery cabinets	Battery cabinet "VSDA 1"	UPS cabinet		
					Dimensions	UPS weight (*)	Shipping weight (*)
LP3-11	10	7	n.a.	n.a.		85kg	100kg
LP5-11	10 *	7 *	-	Dimensions (h \times w \times d): 537 \times 313 \times 590mm Shipping dimensions (h \times w \times d): 800 \times 460 \times 750mm Battery: 240Vdc 7Ah or 14Ahr Weight with battery: 70kg or 120kg Shipping weight: 85kg or 135kg	Cabinet: "VSD1" Dimensions (h \times w \times d): 537 \times 313 \times 590mm (height with wheels) Shipping dimensions: 800 \times 460 \times 750mm	110kg	125kg
	25	14	1				
	45	21	1				
	60	28	2				
LP6-11	8 *	7 *	-		Cabinet: "VSD2" Dimensions (h \times w \times d): 680 \times 313 \times 720mm (height with wheels) Shipping dimensions: 915 \times 460 \times 810mm	115kg	130kg
	21	14 *	1				
	35	21	1				
	50	28	2				
LP8-11	65	35	2		165kg	185kg	
	11 *	12 *	-				
	22	19	1				
	33	26	12				
LP10-11	44	33	2	170kg	190kg		
	55	40	2				
	8 *	12 *	-				
	16	19	1				
	25	26	1				
	34	33	2				
	43	40	2				

(*): Standard backup time and capacity

UPS block diagram, protections and cable sections

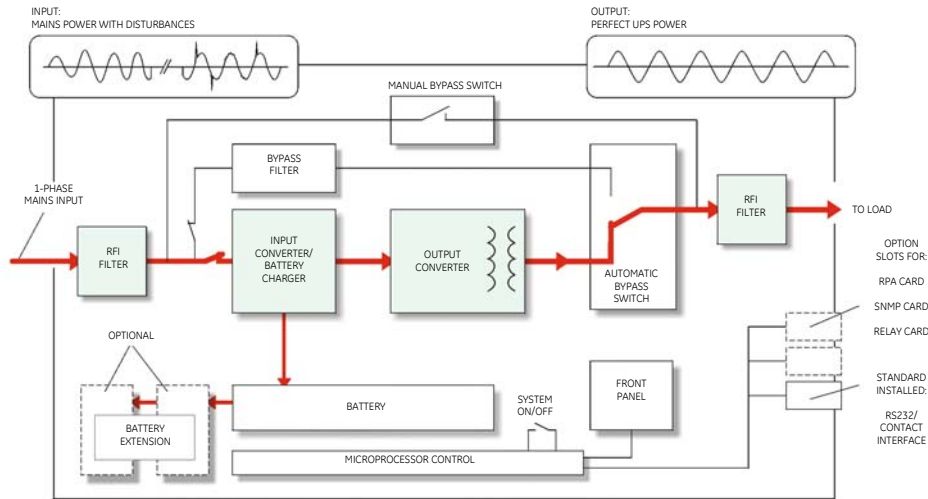

Recommended external fusing of input wiring		Cable sections input and output recommended by European standards / in () SEV Alternatively, local standards to be respected	
UPS Model	Fuses gL/ gG or Automatic Breakers	CABLE SECTIONS	
	Mains / Bypass input	mm ²	AWG
LP3-11	16A	4	12
LP5-11	25A	6	10
LP 6-11	25A	6	10
LP 8-11	50A	10	8
LP 10-11	50A	10	8